

### CONTENTS

Introduction	1
Interchangeability	1
Special Information	2
To Reassemble Model G75 & GG75	5
To Reassemble Model H75, HJ75 & HL75	6
To Reassembly Model G475 & GG475	7
To Reassembly Model H475, HJ475 & HL475	8
Safety Relief Valve Instructions	9
Pressure Adjustment	9

### INTRODUCTION

The illustrations used in this manual are for identification purposes only and *should not be used for ordering parts*. Secure a parts list from the factory or a Vican representative. Always give complete name of part, part number and material, with the model number and serial number of the pump when ordering repair parts. This model number and serial number can be found on the nameplate attached to the pump casing. This is important identification for ordering parts or a replacement pump. It is positive assurance you will receive the correct pump parts.

Your pump is composed of four major parts. Only two of these are moving parts, the rotor and idler.

An exploded parts drawing and list of parts is included to help you identify each part correctly. However to disassembly and reassemble the pump you will be covered step by step. Refer to pages 2 to 9.

### INTERCHANGEABILITY

These pumps are furnished with either a mechanical seal or lip seal.

All models of the mechanical seal pumps and lip seal pumps are dimensionally interchangeable on any NEMA "C" flange motor. The mechanical seal is interchangeable with the lip seal in all pump sizes.

### INSTALLATION

The suction line should be air tight and at least as large as the pump section port connections to prevent loss of prime or capacity. It should also be equipped with a strainer and if pumping light liquids at a high suction lift, a foot or check valve should be used. Always avoid high spots and obstructions in the suction line as these may cause noise, loss of capacity or air lock. Since these pumps are the positive displacement type, be sure there is no obstruction in the discharge line and all valves are in operating position before starting the pump. Be sure the adjusting screw of the relief valve on the pump point towards the suction port. Factory assembled pumps will have right hand port suction and left hand port discharge unless otherwise specified. Port location is determined by looking at mounting flange end of pump. The relief valve on the pump is excellent insurance against a clogged discharge line or closed valves in the discharge line.

UNMOUNTED PUMP MODELS	
WITH LIP SEAL	WITH MECHANICAL SEAL
G75	G475
GG75	GG475
H75	H475
HJ75	HJ475
HL75	HL475

MOUNTED PUMP MODELS			
WITH LIP SEAL	WITH MECHANICAL SEAL	NORMAL GPM	
		@ 2000 RPM	@ 1800 RPM
G75M	G475M	5	7
GG75M	GG475M	7	10
H75M	H475M	10	15
HJ75M	HJ475M	13	20
HL75M	HL475M	20	30

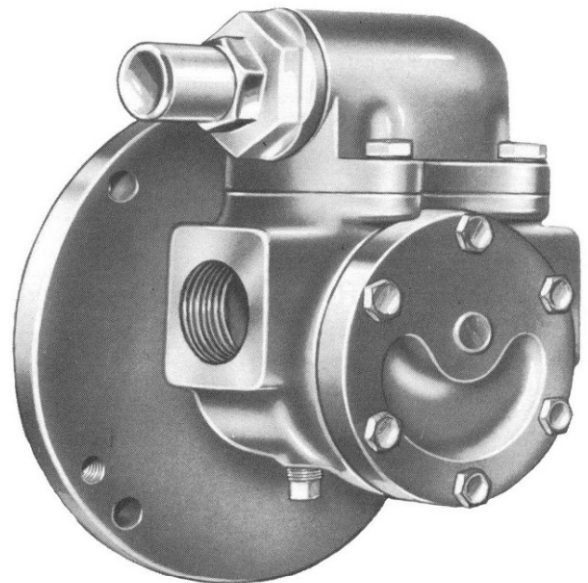

**FIGURE 1  
UNMOUNTED PUMP SHOWING FRONT  
VIEW OF G AND GG SIZE**

## SPECIAL INFORMATION

**ROTATION:** Vican pumps operate equally well in a clockwise or counterclockwise rotation. Shaft rotation determines which port is suction and which is discharge. Port in area where pumping elements (gear teeth) come out of mesh is suction port.

### **PRESSURE RELIEF VALVES:**

1. Vican pumps are positive displacement pumps and must be provided with some sort of pressure protection. This may be a relief valve mounted directly on the pump, an inline pressure relief valve, a torque limiting device or a rupture disk.
2. This series of pumps may be equipped with an integral pressure relief valve. Standard configuration is for clockwise rotation (suction on the right viewing the shaft end of the pump) but it also may be ordered for counter clockwise rotation. The valve cannot be reversed for opposite rotation.
3. If pump rotation is reversed during operation, pressure protection must be provided on *both* sides of pump.
4. Relief valve adjusting screw cap must *always* point towards suction side of pump.
5. Pressure relief valves cannot be used to control pump flow or regulate discharge pressure.

For additional information on pressure relief valves, refer to Technical Service Manual TSM000 and Engineering Service Bulletin ESB-31.

**NOTE:** Lip seal pumps, Model G75, GG75, H75, HJ75, HL75, G75M, GG75M, H75M, HJ75M and HL75M are equipped with an internal suckback arrangement. A small suckback screw (self-locking) is inserted in a hole on the discharge side of the pump. This can be seen through the port opening and behind the rotor, (refer to figure 3). *The hole on the suction side must be left open* to prevent damage to the lip seals. Both holes are plugged in the mechanical seal pump Model G475, GG475, H475, HJ465, HL475, G475M, GG475M, H475M, HJ475M, and HL475M. Since these pumps have only two moving parts and are all performance tested at the factory, they seldom cause trouble. If trouble does occur we always advise investigating all other possible causes before disassembling the pump. Most troubles are caused by air leaks and obstruction in the suction line.

## MAINTENANCE

The Series 75 and 475 pumps are designed for long trouble free life under a wide variety of application conditions, with minimum maintenance, however the following should be considered.

1. **LUBRICATION** – External lubrication not required for this series of pumps. The liquid being pumped lubricates the internal bearings in the pump.
2. **END CLEARANCE ADJUSTMENT** – After long term operation it is sometimes possible to improve the performance of the pump, without major repair, by adjusting the end clearance. Refer to instructions under assembly of the pump for information regarding this procedure.
3. **SAFETY RELIEF VALVE** – If your pump is equipped with a safety relief valve, adjustment can be made as follows. Remove the adjusting screw cap, turn in the adjusting screw to increase the pressure and turn-out to decrease the pressure. If the pump is not producing the rated capacity adjustment of the safety relief valve may be necessary. Be sure adjusting screw cap is re-installed before pump is started.
4. **CLEANING THE PUMP** - It is good practice to keep the pump as clean as possible. This will facilitate inspection, adjustment and repair work.
5. **STORAGE** - If the pump is to be stored or not used for any appreciable length of time it should be drained and a light coat of lubricating and preservative oil should be applied to the internal parts

**SUGGESTED REPAIR TOOLS:** The following tools must be available to properly repair Series 75 and 475 pumps. These tools are in addition to standard mechanics' tools such as open end wrenches, pliers, screw drivers, etc. Most of the items can be obtained from an industrial supply house.

1. Soft Headed hammer
2. Allen wrenches (some mechanical seals and set collars)
3. Mechanical seal installation sleeve
4. Brass bar
5. Arbor press

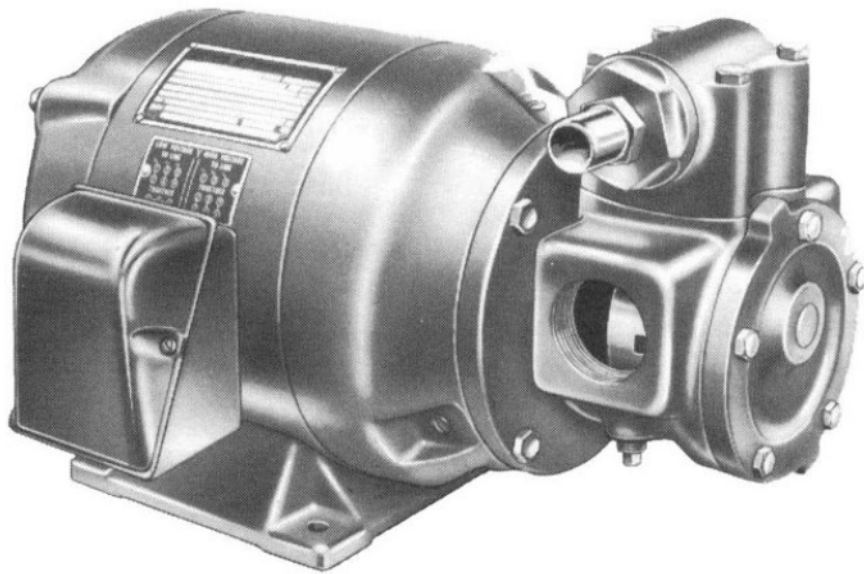

**FIGURE 2**  
**MOTOR MOUNTED PUMP SHOWING**  
**H, HJ AND HL SIZE**

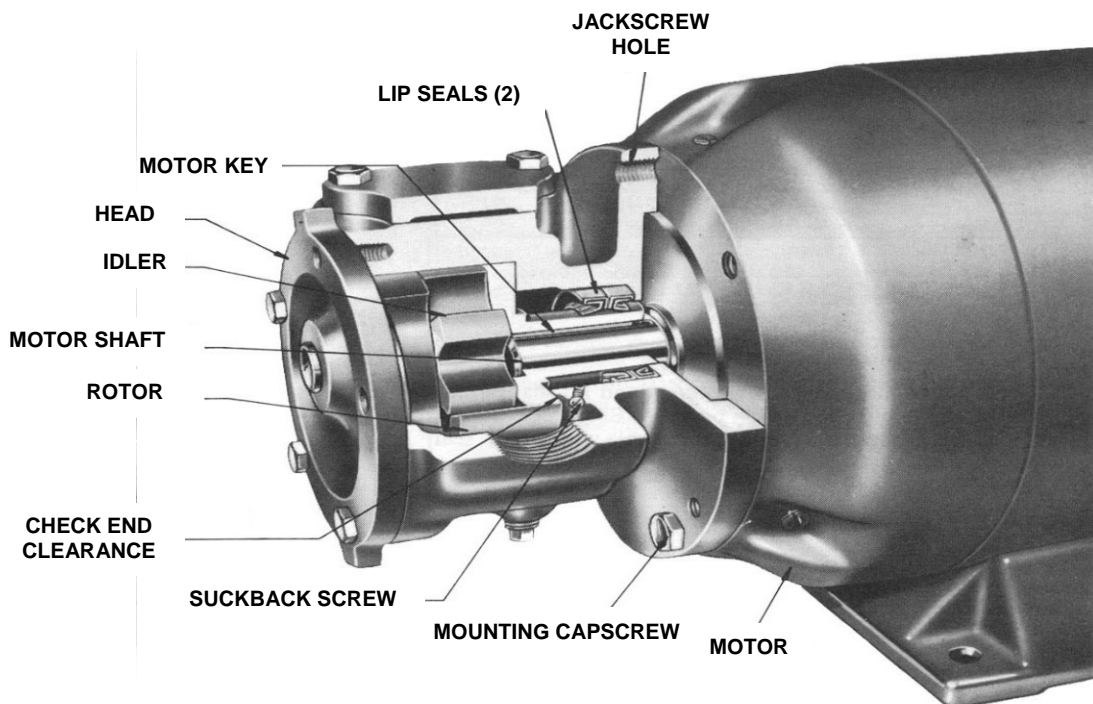

**FIGURE 3**  
**CUTAWAY OF H, HJ AND HL 75**  
**LIP SEAL PUMP**

## DISASSEMBLY

### DANGER

BEFORE OPENING ANY VICAN PUMP LIQUID CHAMBER (PUMPING CHAMBER, RESERVOIR, RELIEF VALVE ADJUSTING CAP FITTING ETC.) BE SURE:

1. THAT ANY PRESSURE IN CHAMBER HAS BEEN COMPLETELY VENTED THROUGH SUCTION OR DISCHARGE LINES OR OTHER APPROPRIATE OPENINGS OR CONNECTIONS.
2. THAT THE DRIVING MEANS (MOTOR, TURBINE, ENGINE, ETC.) HAS BEEN "LOCKED OUT" OR MADE NON-OPERATIONAL SO THAT IT CANNOT BE STARTED WHILE WORK IS BEING DONE ON PUMP.
3. THAT YOU KNOW WHAT LIQUID THE PUMP HAS BEEN HANDLING AND THE PRECAUTIONS NECESSARY TO SAFELY HANDLE THE LIQUID. OBTAIN A MATERIAL SAFETY DATA SHEET (MSDS) FOR THE LIQUID TO BE SURE THESE PRECAUTIONS ARE UNDERSTOOD.

FAILURE TO FOLLOW ABOVE LISTED PRECAUTIONARY MEASURES MAY RESULT IN SERIOUS INJURY OR DEATH.

1. REMOVE THE PUMP FROM THE MOTOR. Remove the four capscrews and use three as jackscrews in the threaded holes of the pump from motor shaft.  
NOTE: If the pump has a valve it must be removed first to have room for the jackscrews.
2. REMOVE PUMP HEAD.  
NOTE: Mark the head and casing before disassembly to make sure they are reassembled properly. The idler pin, which is offset in the pump head, should be properly positioned toward and equal distance between the port connections to allow for proper flow of liquid through the pump.  
If it is necessary to disassemble the pump for inspection or repair, first remove the head capscrews and remove head by tapping the head removing lugs lightly.

### CAUTION

WHEN THE HEAD IS BEING REMOVED, THE IDLER USUALLY STAYS ON THE IDLER PIN. AVOID TILTING THE INSIDE OF THE HEAD DOWNWARD, AS THE IDLER MAY SLIDE OFF THE IDLER PIN AND FALL. A FALL ON A HARD SURFACE CAN DAMAGE THE IDLER. IF THE IDLER SHOULD FALL, CHECK CAREFULLY AND FILE OR STONE ALL NICKED OR ROUGH PLACES BEFORE REASSEMBLY.

3. REMOVE THE HEAD GASKETS. If a new set is not available, the original gaskets may be reused provided they are not damaged.
4. REMOVE THE IDLER FROM THE IDLER PIN. If idler pin is worn, both the head, idler pin and idler bushing should be replaced.  
If the idler bushing is worn, a new bushing is needed.  
If the new bushing is carbon graphite, special care must be taken when pressing it into the idler. An arbor press should always be used; be sure the bushing is started straight. DO NOT STOP the pressing operation until bushing is in its proper location. Carbon graphite is brittle; starting and stopping the pressing operation frequently results in a cracked bushing. If cracked in the idler, the bushing, will quickly disintegrate.
5. REMOVE THE ROTOR FROM THE CASING. The rotor of the two smaller pumps (G & GG sizes) can be removed by pressing of the end of hollow drive end of the rotor. It will be necessary on the models with mechanical seals (G475 & GG475) to use an arbor press and an arbor of approximately 1.375" diameter. The seal will remain in the casing.  
The rotor of the three larger size pumps (H, HJ, HL sizes) can also be removed by pushing on the hollow drive end of the rotor. The spring and rotary member of the mechanical seal will come out with the rotor in these pumps.
6. REMOVE THE MECHANICAL SEAL OR LIP SEALS. (See figure 4) Remove the snap ring in the casing of the two smaller pumps (G and GG sizes) and the complete seal can be removed out of the large flanged end of the casing.  
Remove the spring and rotary member from the rotor and the seal seat or lip seals from the pump end of the casing of the three larger size pumps (H, HJ, HL).

## REASSEMBLY

Reassembly of these pumps is explained by one of the following sets of instructions. Follow the instructions for the proper pump model.  
Before starting to reassemble the pump, clean all parts thoroughly and replace those, which show signs of excessive wear or damage.

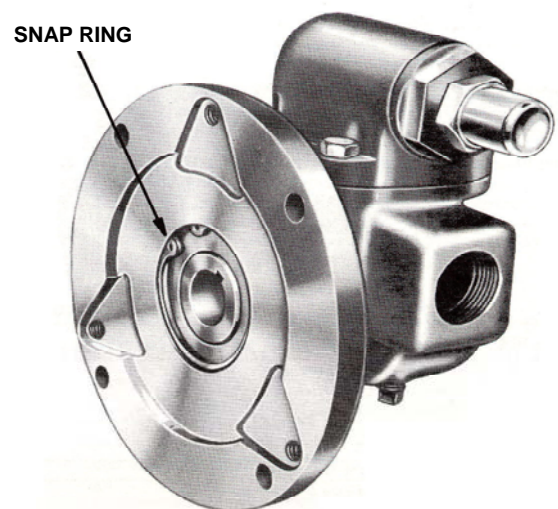
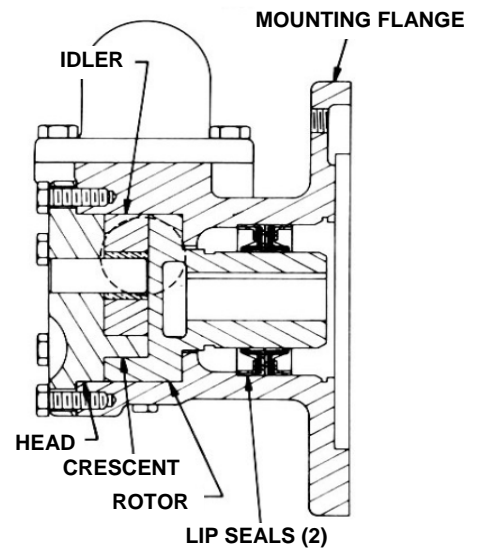

FIGURE 4  
VIEW OF FLANGE END OF G AND  
GG475 MECH. SEAL PUMPS

**To Reassemble Model G75 or GG75  
Lip Seal Pumps: (see Figure 7)**

1. INSTALL THE LIP SEALS. The lip seals should be installed in the casing one at a time from the large flanged end. The sealing lips must face away from each other.  
**NOTE:** Use an arbor press with an arbor of 2.188 diameter and press the lip seals in the casing as far as the will go. See figures 7, 8, 9, and 10 for a cross section of your pump models.
2. LUBRICATE THE LIP SEALS. Fill the area between the lips of the lip seals with grease.
3. INSTALL THE ROTOR. Flush the rotor hub with light oil (not grease) and insert the rotor in the casing with the hub through the lip seals.

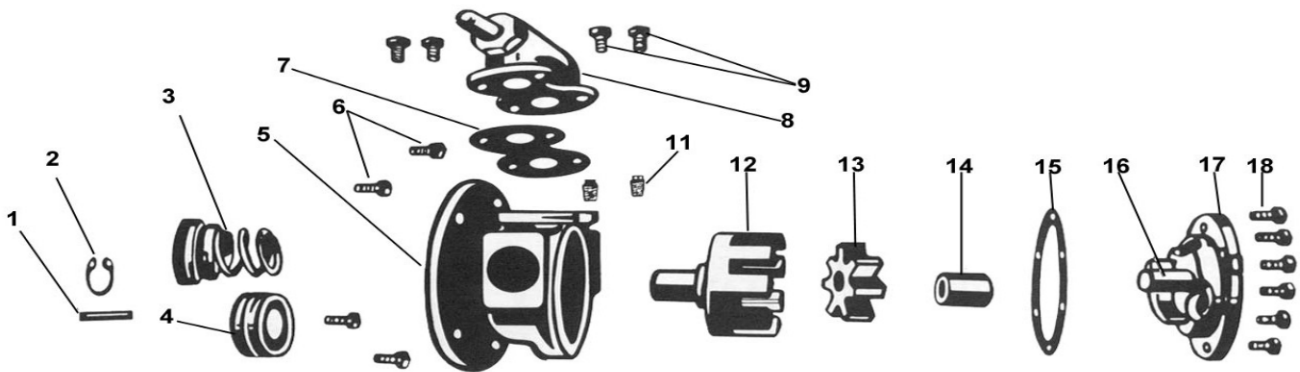

**FIGURE 7  
SECTIONAL DRG. OF MODELS G75, GG75  
LIP SEAL PUMPS**

**CAUTION**

TURN THE ROTOR BACK AND FOURTH AS YOU EXERT ENOUGH FORCE TO PUSH IT THROUGH THE LIP SEAL AND TO THE BOTTOM OF THE CASING. BE CAREFUL NOT TO FOLD UNDER THE LIP OF THE INNER SEAL.

4. INSTALL THE IDLER. Put the idler with the bushings on the idler pin.
5. PLACE HEAD GASKETS ON THE PUMP HEAD. The proper amount of gaskets should be used to provide necessary end clearance within the pump so it turns freely with no appreciable end play. Gasket table 1 gives the normal amount of gaskets used.
6. THE HEAD CAN NOW BE ASSEMBLED ON THE PUMP. Tilt the top of the head away from the pump slightly until the crescent enters the inside diameter of the rotor and rotate the idler until its teeth mesh with the rotor teeth. Do not damage the head gaskets. Note correct position of idler and crescent (See figure 7 and Disassembly step 2). Tighten the head capscrews and then check the end clearance.



**FIGURE 5  
EXPLODED VIEW SERIES 75 & 475 PUMPS (G AND GG SIZE)**

ITEM	NAME OF PART	ITEM	NAME OF PART
1	Key for Motor Shaft (Full Length)	10	Pipe Plugs-1/8"
2	Snap Ring (Used with Mech. Seal Pumps Only)	11	Machine Screw (2 for Mech. Seal Pump, 1 for Lip Seal Pump)
3	Mechanical Seal (Complete)	12	Rotor
4	Lip Seal (2)	13	Idler
5	Casing	14	Idler Bushings
6	Capscrews (Pump on Motor)	15	Gasket (for Head)
7	Gasket For Relief Valve or Cover Plate)	16	Idler Pin
8	Relief Valve	17	Head
9	Capscrews (For Relief Valve or Cover Plate)	18	Capscrews (For Head)

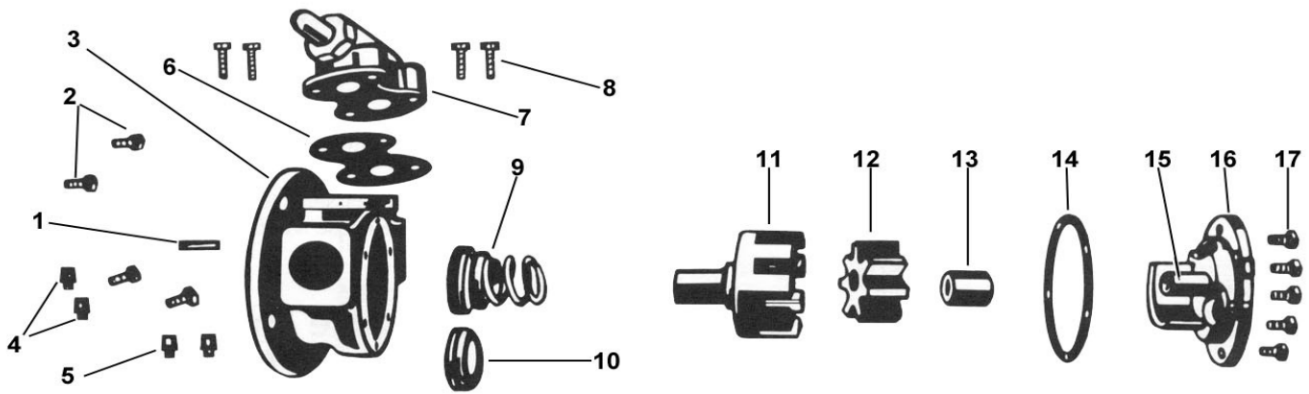

**FIGURE 6**  
**EXPLODED VIEW SERIES 75 & 475 PUMPS (H, HJ AND HL SIZE)**

ITEM	NAME OF PART	ITEM	NAME OF PART
1	Key for Motor Shaft (Full Length)	10	Lip Seal (2)
2	Capscrew (Pump to Motor)	11	Rotor
3	Casing	12	Idler
4	Machine Screw (2 for Mech. Seal Pump, 1 for Lip Seal Pump)	13	Idler Bushing
5	Pipe Plugs-1/8"	14	Gasket (For Head)
6	Gasket (For Relief Valve or Cover Plate)	15	Idler Pin
7	Relief Valve	16	Head
8	Capscrews (For Relief Valve or Copper Plate)	17	Capscrews (For Head)
9	Mechanical Seal (Complete)		

7. CHECK PUMP END CLEARANCE. Measure clearance between the back of the rotor and the mechanical surface in the bottom of the casing by inserting a feeler gauge through the port opening. This is the end clearance; normal amount is 0.003" to 0.005". Add or remove gaskets until the figure is reached.

9. ASSEMBLE THE PUMP ON THE MOTOR. Install the full length key in the keyway of the motor shaft.  
 NOTE: Key must be full length to avoid misalignment of the pump rotor, which could cause serious damage to the pump. Slide the pump on the motor shaft and fasten securely with the four capscrews.

**GASKET TABLE 1**

PUMP MODELS	NORMAL AMOUNT USED (Inch)	ONE SET OF GASKETS CONSISTS OF THE FOLLOWING
G75 AND GG75 Lip Seal Pumps	.010" - .015"	2 - .005" Plastic 3 - .002" Plastic

8. BOLT THE VALVE INTO CASING. Place the valve gasket and valve or cover-plate on the pump and fasten securely with the four capscrews.

**To Reassemble Model H75, HJ75, or HL75 Lip Seal Pumps: (See Figure 8)**

1. INSTALL THE LIP SEALS. The lip seals should be installed in the casing one at a time from the head end. The sealing lips must face away from each other.  
**NOTE:** Use an arbor press of 2.188 diameter and press the lip seals in the casing as far as they will go.
2. LUBRICATE THE LIP SEALS. Fill the area between the lips and the lip seals with grease.
3. INSTALL THE ROTOR. Flush the rotor hub with light oil (not grease) and insert the rotor in the casing with the hub through the lip seals.

**CAUTION**

BE SURE THE ADJUSTING SCREW OF THE RELIEF VALVE POINTS TOWARD THE SUCTION PORT.

**CAUTION**

TURN THE ROTOR BACK AND FOURTH AS YOU EXERT ENOUGH FORCE TO PUSH IT THROUGH THE LIP SEAL AND TO THE BOTTOM OF THE CASING. BE CAREFUL NOT TO FOLD UNDER THE LIP OF THE INNER SEAL.

4. INSTALL THE IDLER. Put the idler with bushing on the idler pin.
5. PLACE THE HEAD GASKETS ON THE PUMP HEAD. The proper amount of gaskets should be used to provide the necessary end clearance within the pump so it turns freely with no appreciable end play. Gasket Table 2 gives the normal amount of gaskets used.
6. THE HEAD CAN NOW BE ASSEMBLED ON THE PUMP. Tilt the top of the head away from the pump slightly until the crescent enters the inside diameter of the rotor and rotate the idler until its teeth mesh with the rotor teeth. Do not damage the head gaskets. Note correct position of idler and crescent. (See Figure 8 and Disassembly Step 2). Tighten the head capscrews and then check the end clearance.
7. CHECK PUMP END CLEARANCE. Measure the clearance between the back of the rotor and the machined surface in the bottom of the casing by inserting a feeler gauge through the port opening. This is the end clearance. Normal amount is 0.003" to 0.005". Add or remove gaskets until the figure is reached.

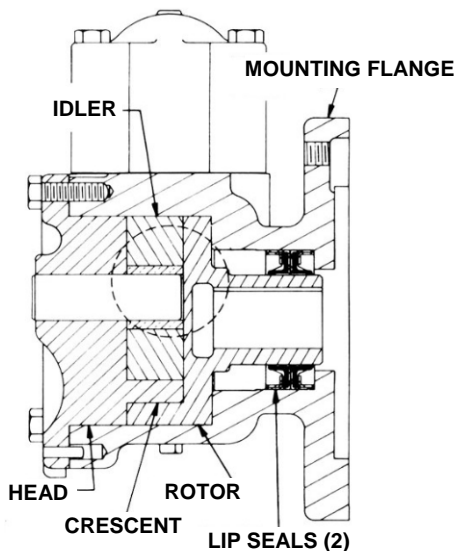

**FIGURE 8**  
SECTIONAL DRG. OF MODELS H75, HJ75  
AND HL75 LIP SEAL PUMPS

**GASKET TABLE 2**

PUMP MODELS	NORMAL AMOUNT USED (Inch)	ONE SET OF GASKETS CONSISTS OF THE FOLLOWING
H75, HJ 75 And HL75 Lip Seal Pumps	.010" - .015"	2 - .002" Plastic 2 - .006" Paper

8. BOLT THE VALVE TO THE CASING. Place the valve gasket and valve or coverplate on the pump and fasten securely with the four capscrews.

**CAUTION**

BE SURE THE ADJUSTING SCREW OF THE RELIEF VALVE POINTS TOWARD THE SUCTION PORT.

9. ASSEMBLE THE PUMP ON THE MOTOR. Install the full length key in the keyway of the motor shaft.  
NOTE: Key must be full length to avoid misalignment of the pump rotor, which could cause serious damage to the pump. Slide the pump on the motor shaft and fasten securely with the four capscrews.

**To Reassemble Model G475 or GG475 Mechanical Seal Pumps: (see figure 9)**

1. INSTALL THE ROTOR IN THE CASING.
2. INSTALL THE IDLER. Put the idler with bushing on the idler pin.
3. PLACE THE HEAD GASKET ON THE HEAD. The proper amount of gaskets should be used to provide the necessary end clearance within the pump so it turns freely with no appreciable end play. Gasket Table 3 gives the normal amount of gaskets used.

**GASKET TABLE 3**

PUMP MODELS	NORMAL AMOUNT USED (Inch)	ONE SET OF GASKETS CONSISTS OF THE FOLLOWING
G475 And GG475 Mech. Seal Pumps	.010" - .015"	2 - .005" Plastic 3 - .002" Plastic

4. THE HEAD CAN NOW BE ASSEMBLED ON THE PUMP. Tilt the top of the head away from the pump slightly until the crescent enters the inside diameter of the rotor and rotate the idler until its teeth mesh with the rotor teeth. Do not damage the head gaskets. Note correct position of idler and crescent (see figure 9 and Disassembly Step 2). Tighten the head capscrews and the check the end clearance.
5. CHECK PUMP END CLEARANCE. Measure the clearance between the back of the rotor and the machined surface in the bottom of the casing by inserting the feeler gauge through the port opening. This is the end clearance. Normal amount is 0.003" to 0.005". Add or remove gaskets until the figure is reached.

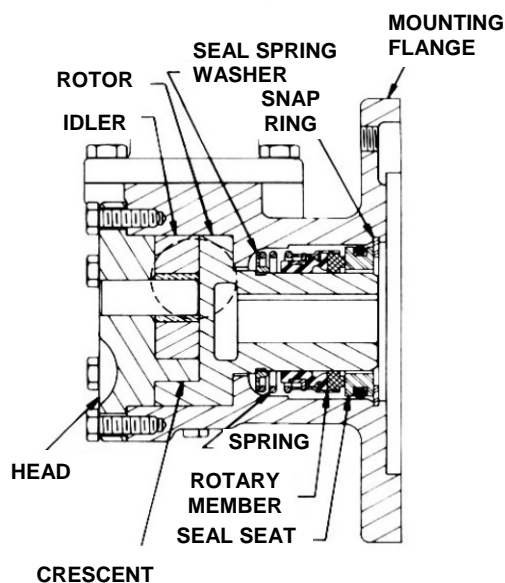

**FIGURE 9**  
**SECTIONAL DRG. OF MODELS G475 & GG475**  
**MECH. SEAL PUMPS**

6. INSTALL THE MECHANICAL SEAL. Slide the seal spring washer over the rotor hub as far as it will go. Flush the rotor hub and seal housing bore with light oil (not grease) and assemble spring, rotary member and seat of the mechanical seal; in position, refer to figure 9.

#### **CAUTION**

NEVER TOUCH THE SEALING FACES OF THE MECHANICAL SEAL WITH ANYTHING EXCEPT FINGERS OR A CLEAN CLOTH.

7. INSTALL THE SNAP RING. Install the snap ring in the groove in the casing. This will hold the seal at its proper working length.
8. BOLT THE VALVE TO THE CASING. Place the valve gasket and valve or coverplate on the pump and fasten securely with the four capscrews.

#### **CAUTION**

BE SURE THE ADJUSTING SCREW OF THE RELIEF VALVE POINTS TOWARD THE SUCTION PORT.

9. ASSEMBLE THE PUMP ON THE MOTOR. Install the full length key in the key way of the motor shaft.  
**NOTE:** Key must be *full* length to avoid misalignment of the pump, which could cause serious damage to the pump. Slide the pump on the motor shaft and fasten securely with the four capscrews.

#### **To Reassemble Model H475, HJ475, or HL475 Mechanical Seal Pumps: (See Figure 10)**

1. INSTALL THE SEAL SEAT. Lubricate the outside diameter of the seal seat and the inside of the seal seat and the inside of the seal housing bore with the light oil (not grease). Start the seal seat in the casing and press into place.

#### **CAUTION**

NEVER TOUCH THE SEALING FACES OF THE MECHANICAL SEAL WITH ANYTHING EXCEPT FINGERS OR A CLEAN CLOTH.

2. INSTALL THE ROTARY MEMBER OF SEAL. Flush the rotor hub and the inside of the rotary member with light oil. Slide the spring and rotary member over the rotary hub only far enough to hold the spring in position. Do not compress the spring at this time.
3. INSTALL THE ROTOR IN THE CASING.
4. INSTALL THE IDLER. Put the idler with the bushing on the idler pin.
5. PLACE THE HEAD GASKETS ON THE HEAD. The proper amount of gaskets should be used to provide the necessary end clearance within the pump so it turns freely with no appreciable end play. Gasket Table four gives the normal amount of gaskets used.
6. THE HEAD CAN NOW BE ASSEMBLED ON THE PUMP. Tilt the head away from the pump slightly until the crescent enters the inside diameter of the rotor and rotate the idler until its teeth mesh with the rotor teeth. Do not damage the head gaskets. Note correct position of idler and crescent. Refer to figure 10 and disassembly step 2.

**GASKET TABLE 4**

PUMP MODELS	NORMAL AMOUNT USED (Inch)	ONE SET OF GASKETS CONSISTS OF THE FOLLOWING
H475, HJ475 & HL475 Mechanical Seal Pumps	.010" - .015"	2 - .002" Plastic 2 - .006" Paper

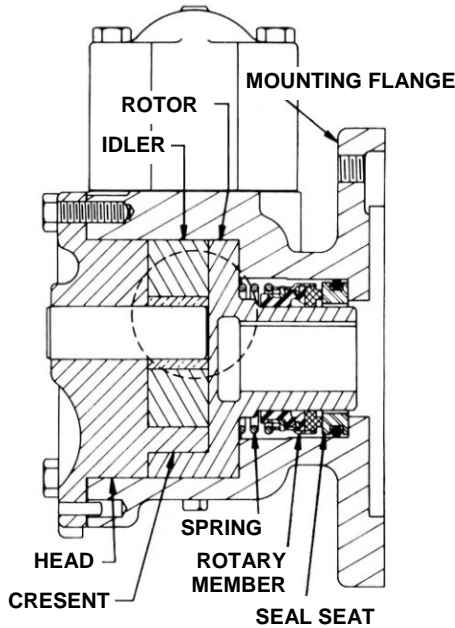

**FIGURE 10  
SECTION DRG. OF MODELS H475, HJ 475  
AND HL 475 MECH. SEAL PUMPS**

- CHECK PUMP END CLEARANCE. Measure the clearance between the back of the rotor and the machined surface in the bottom of the casing by inserting a feeler gauge through the port opening. This is the end clearance; normal amount is 0.003" and 0.005". Add or remove gaskets until the figure is reached.
- BOLT THE VALVE INTO THE CASING. Place the valve gasket and valve or coverplate on the pump and fasten securely with the four capscrews.

**CAUTION**

BE SURE THE ADJUSTING SCREW OF THE RELIEF VALVE POINTS TOWARD THE SUCTION PORT.

- ASSEMBLE THE PUMP ON THE MOTOR. Install the length key in the keyway in the motor shaft.  
NOTE: Key must be full length to avoid misalignment of the pump, which could cause serious damage to the pump. Slide the pump on the motor shaft and fasten securely with the four capscrews.

**SAFETY RELIEF VALVE INSTRUCTIONS**

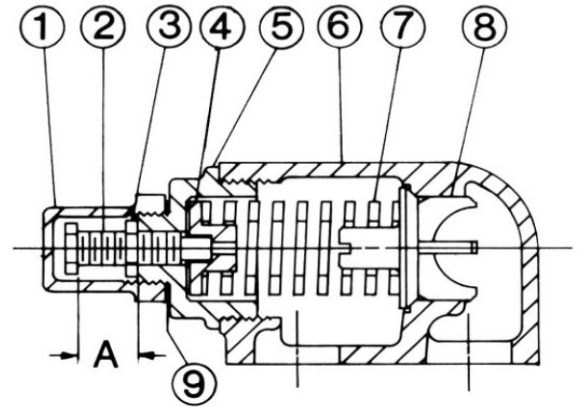

**FIGURE 11  
VALVE – G, GG, H, HJ AND HL SIZE**

LIST OF PARTS	
1. Valve Cap	6. Valve Body
2. Adjusting Screw Cap	7. Valve Spring
3. Lock Nut	8. Poppet
4. Spring Guide	9. Cap Gasket
5. Bonnet	

**DISASSEMBLY**

**NOTE:** Mark valve and head to be sure they are reassembled in the same relative position.

- Remove valve cap.
- Measure and record the length of extension of the adjusting screw. See "A" on figure 11.
- Loosen the lock nut and back out adjusting screw until spring pressure is released.
- Remove bonnet, spring guide, spring and poppet from valve body. Clean and inspect all parts for wear or damage and replace as necessary.

**ASSEMBLY**

Follow the procedure outlined under disassembly. If valve is removed for repairs, be sure to replace in same position. The valve cap should point towards the suction port.

## PRESSURE ADJUSTMENT

If the pressure setting of the safety relief valve is to be changed from that which the factory has set, the following instructions should be carefully followed:

1. Remove the valve cap, which covers the adjusting screw, and loosen the lock nut that locks the adjusting screw so pressure setting will not change during operation of pump.
2. A pressure gauge somewhere in the discharge line must be used for actual adjustment operation.
3. The adjusting screw should be turned in for increasing the pressure or turned out for decreasing the pressure.
4. With the discharge line closed at a point beyond the pressure gauge, the gauge will show the maximum pressure the valve will allow while pump is in operation.

## IMPORTANT

In ordering parts for pressure relief valve, always give model number and serial number of pump as it appears on nameplate and name of part wanted. When ordering springs, be sure to give pressure settings desired.

# VICAN PUMP

## WARRANTY

The company warrants all products manufactured by it to be free from defects in workmanship or material for a period of one (1) year from date of startup, provided that in no event shall this warranty extend more than eighteen (18) months from the date of shipment from the company. If, during said warranty period, any products sold by the company prove to be defective in workmanship or material under normal use and service, and if such products are returned to the company, transportation charges prepaid, and if the products are found by the company to be defective in workmanship or material, they will be replaced or repaired free of charge, F.O.B. the company location.

The company assumes no liability for consequential damages of any kind and the purchaser by acceptance of delivery assumes all liability for the consequences of the use or misuse of the company products by the purchaser, his employees or others. The company will assume no field expense for service or parts unless authorized by it in advance.

Equipment and accessories purchased by the company from outside sources which are incorporated into any company product are warranted only to the extent of and by the original manufacturer's warranty or guarantee, if any.

THIS IS THE COMPANY'S SOLE WARRANTY AND IS IN LIEU OF ALL OTHER WARRANTIES, EXPRESSED OR IMPLIED, WHICH ARE HEREBY EXCLUDED, INCLUDING IN PARTICULAR ALL WARRANTIES OF MERCHANTABILITY OR FITNESS FOR A PARTICULAR PURPOSE.

**No officer or employee of IDEX Corporation or the company is authorized to alter this warranty.**

©2004 All Rights Reserved

®Vican Pump is a registered trademark of Viking Pump of Canada